

A Review of the Current Development Status of Electromagnetic Induction and Magnetic Coupled Resonance Technologies in Wireless Charging for Electric Vehicles

Yiran Zhu

ULisboa School of Shanghai University, Shanghai University, Shanghai, China
zyr44556@163.com

Abstract

With the rapid development of electric vehicles (EVs), wireless charging technology has become a research hotspot because of its convenience and safety. This paper reviews the current situation of electromagnetic induction and magnetic resonance coupling technology for wireless charging of electric vehicles, and analyzes their technical principles, characteristics and application scenarios. Electromagnetic induction technology is based on Faraday's law of electromagnetic induction, which realizes efficient short-distance energy transmission through magnetic coupling between primary and secondary coils, and is suitable for static charging scenarios. Magnetic resonance coupling technology optimizes transmission distance and efficiency through resonant network, which is suitable for dynamic charging and complex environment. These two technologies have their own advantages and disadvantages in charging efficiency, transmission distance and electromagnetic radiation safety, and can complement each other. By optimizing the coil design, compensation network and control strategy, the performance of these technologies is constantly improving, which provides important support for the intelligent and sustainable development of EV. Future research should solve the problems of efficiency loss, cost reduction and electromagnetic compatibility, so as to promote the wide application of wireless charging technology.

Keywords: Electromagnetic induction, Magnetic resonance coupling, Electric vehicle, Wireless charging, Energy transfer

1. Introduction

1.1 Research Background and Significance

With the global energy crisis and environmental pollution becoming more and more serious, electric vehicles (EVs), as a low-carbon and environmentally friendly mode of travel, have become an important development direction of the automobile industry. The exhaust gas emitted by traditional fuel vehicles is the main cause of air pollution and climate change, and EVs is the key technology to realize sustainable development because of its zero emission and low noise. However, the large-scale promotion of EVs also faces challenges in terms of charging convenience and safety. The traditional wired charging method has some safety problems, such as plug wear, spark risk, tripping hazard and so on, which affects the user experience and the popularization of charging facilities. Wireless charging technology allows us to charge without plugging in the wire, which greatly improves the convenience and safety of charging, and also provides a new method for the widespread use of electric vehicles (EV) [1]. In particular, electromagnetic induction and magnetic resonance coupling have become the focus of research because of their high efficiency and wide use. Wireless charging not only makes our experience better, but also promotes the development of intelligent transportation and autonomous driving technology; For example, dynamic wireless charging can make the car replenish energy when driving [4]. Therefore, it is very important to deeply study the present situation of electromagnetic induction and magnetic resonance coupling technology to promote the technological progress and market popularization of EV industry.

1.2 Overview of Wireless Charging Technology for Electric Vehicles

The wireless charging technology of electric vehicle can transmit electricity without contact by changing electric energy into electromagnetic field or electromagnetic wave. There are two main technologies: one is electromagnetic induction, and the other is magnetic resonance. Electromagnetic induction technology is based on Faraday's law of electromagnetic induction, which uses a changing magnetic field between the primary coil and the secondary coil to transmit electricity, which is suitable for static charging in the parking lot with short distance and high efficiency. Magnetic resonance technology, on the other hand, makes the distance and efficiency of power transmission better through something called resonant network, overcomes the limitation of short electromagnetic induction transmission, can effectively transmit power within a few meters, and is suitable for charging while driving (dynamic charging) and more complicated environment [4]. Both of these technologies need rectification, filtering and high-frequency inverter circuits. First, the AC power of the power grid is converted into a signal suitable for transmission, and then it is converted back to DC power at the receiving end to charge the battery [2]. Recent research mainly wants to improve charging efficiency, increase transmission distance and reduce electromagnetic radiation, so technology has made rapid progress. For example, various coupling compensation networks (SS, PS, SP, PP, etc.) have been developed to make the system more stable and efficient [4]. The rapid development of wireless charging technology has laid a technical foundation for the intelligence and convenience of electric vehicles, and also promoted the standardization and industrialization of this technology [3].

2. Principles of Wireless Charging Technology

2.1 Principle of Electromagnetic Induction Technology

Electromagnetic induction technology is the main technology of wireless charging electric vehicle. Its working principle is based on Faraday's law of electromagnetic induction: if the magnetic flux passing through a conductor changes, induced electromotive force and current will be generated in the conductor. This system mainly includes ground-mounted primary coil and vehicle-mounted secondary coil. Power is transmitted wirelessly through the coupling between them (that is, magnetic coupling). At first, it is the alternating current of the power grid, which is converted into direct current through rectifier and filter circuit, and then into high-frequency alternating current energy through high-frequency inverter. It will produce a changing magnetic field, that is, a high-frequency AC current. According to the action of current on the magnet, this changing magnetic field will induce changing magnetic flux, thus generating AC electricity. Finally, the AC current obtained from the secondary coil is rectified, filtered and processed by the control circuit, and becomes stable DC electricity to charge the battery of the electric vehicle [5]. The advantages of electromagnetic induction technology are relatively simple structure and high energy conversion efficiency, especially in the case of static charging and short coil distance (such as 10-20 cm), the energy conversion efficiency can reach above 85% [6]. However, the transmission distance of this technology will be limited by the attenuation of magnetic field, which requires accurate alignment of coils and can't penetrate too many obstacles, so it can't be used well in dynamic charging. In recent years, researchers have further improved the efficiency and stability by optimizing the coil design and control strategy, and provided reliable technical support for the static wireless charging of electric vehicles [5]. According to Faraday's law of electromagnetic induction, when the magnetic flux passing through a conductor changes, an induced current will be generated in the conductor, which is the basis of electromagnetic induction technology. Electric energy can be transmitted wirelessly through electromagnetic induction, such as installing a primary coil under the ground and a secondary coil inside the electric car, as shown in Figure 1.

Figure 1: Schematic diagram of a wireless charging system based on electromagnetic induction technology

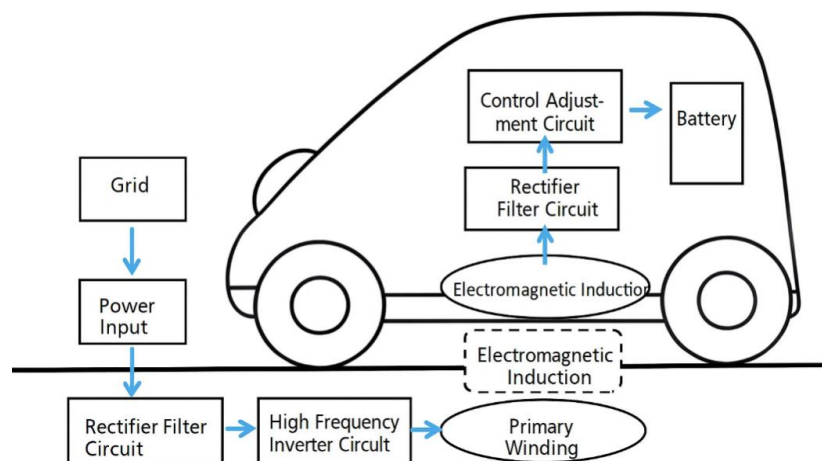

2.2 Principle of Magnetic Resonance Coupling Technology

Magnetic resonance coupling technology improves the distance and efficiency of energy transmission by adding resonance network, which is the extension and development of electromagnetic induction technology. Its core lies in the resonant circuit composed of primary coil, secondary coil and capacitor, which resonates at a specific frequency and realizes efficient energy transmission. The working process is similar to electromagnetic induction: the alternating current of the power grid is rectified and filtered, and then becomes a high-frequency alternating current signal through a high-frequency inverter, which drives the primary coil to generate a resonant magnetic field. When the resonant frequency of the secondary coil matches that of the primary coil, energy can be efficiently transferred to the secondary side through magnetic coupling, and then the battery can be charged through rectification and power control [7]. A great breakthrough of magnetic resonance coupling technology is that it can transmit energy at a longer distance (for example, more than 1 meter), the efficiency can reach 40% to 80%, and it can easily pass through obstacles, so it is very suitable for charging moving things or in complex environments [8]. In order to make the transmission effect better, researchers invented various compensation networks, such as SS, PS, SP and PP, and matched the mutual inductance by adjusting the parameters of capacitors and coils, so that the system was more stable and efficient [7]. Although magnetic resonance coupling technology is more powerful than electromagnetic induction technology in transmission distance and flexibility, its circuit design is very complicated, which requires high accuracy of frequency control and coil alignment, so the cost of the system is higher [8]. Figure 2 shows the path of energy transmission from the power grid to the battery, including LC compensation circuit and high frequency inverter, as well as the resonant coupling process between the primary coil and the secondary coil.

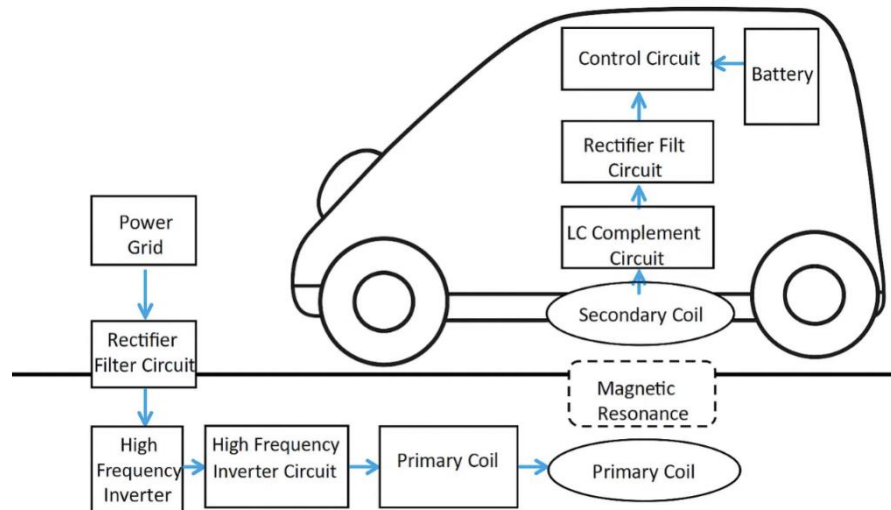
Figure 2: Flowchart of a Wireless Charging System using Magnetic Resonance Coupling Technology

3. Technical Features and Performance Comparison

3.1 Charging Efficiency Analysis

Charging efficiency is a key index to evaluate the wireless charging technology of electric vehicles, which directly affects energy consumption and practicality. Electromagnetic induction technology is very efficient in short distance (usually 10-20 cm), which can reach 85%-90%, thanks to simple coil design and strong magnetic coupling. However, when the distance is far away, the efficiency will drop rapidly, and the misalignment of the coils will also affect the charging effect [9]. In order to improve efficiency, the research focuses on optimizing coil shape and using high frequency inverter technology to reduce energy loss. In contrast, magnetic resonance technology can maintain the efficiency of 40%-80% at a longer distance (0.5-2 meters), because it uses a resonant network (such as SS or PS topology) to match the mutual inductance of coils, which greatly reduces the energy loss in transmission [10]. However, this technology needs to accurately control the resonance frequency, and frequency deviation will lead to efficiency decline. In addition, both technologies will be affected by load changes; Electromagnetic induction is more sensitive because it uses series circuit design, and magnetic resonance can partially solve this problem through compensation network [9]. Recent research shows that combining adaptive control algorithm with new materials (such as high permeability ferrite) can further improve the efficiency of these two technologies and pave the way for their commercial application in wireless charging of electric vehicles [10].

3.2 Charging Distance and Applicable Scenarios

Charging distance is a key difference between electromagnetic induction and magnetic resonance technology, which directly determines where they can be used. The effective transmission distance of electromagnetic induction is usually 10-20 cm, which is suitable for static charging, such as the fixed charging station in the garage or parking lot at home. Because it has strict requirements on coil alignment, it is suitable for vehicle charging at a fixed position, but not for charging while opening [11]. Magnetic resonance technology greatly extends the transmission distance to 1-2 meters through resonance, and is less sensitive to coil dislocation and obstacles (such as air or nonmetallic materials). This makes it more suitable for dynamic charging (such as buried charging coil on the road) and static charging in complex environment (such as public parking lot) [12]. For example, dynamic charging can charge cars when they are driving, greatly increasing their battery life. However, when the transmission distance is long, the efficiency will usually decrease, which needs to be balanced by optimizing the compensation network and coil design [11]. These two technologies complement each other; Electromagnetic induction is more suitable for high-efficiency and short-distance static charging, while magnetic resonance provides technical support for dynamic charging and flexible scenes, which makes the charging methods of electric vehicles more diversified [12].

3.3 Electromagnetic Radiation and Safety Assessment

Electromagnetic radiation and safety are the key issues that wireless charging technology can be widely used. Electromagnetic induction technology, because of its short transmission distance, low electromagnetic field intensity and small radiation range, usually conforms to international electromagnetic compatibility standards (such as ICNIRP guidelines), so it has little impact on us and the environment [13]. However, high-power charging may make the local electromagnetic field stronger, which requires shielding technology and optimized coil design to reduce radiation leakage. Magnetic resonance technology has longer transmission distance and wider electromagnetic distribution range, so it is more challenging to control radiation. Studies have shown that its high-frequency resonant magnetic field may interfere with nearby electronic equipment, and long-term contact may also cause health concerns [14]. In order to ensure safety, the system usually uses shielding materials (such as metal shields) and dynamic power control to limit electromagnetic radiation. Standardized safety assessment methods and regulations (such as IEEE C95.1) provide guidance for technical development [13]. At present, the research focus is on developing low radiation coil structure and real-time monitoring system, which can not only ensure efficient

charging, but also reduce the electromagnetic radiation that people and the environment are exposed to, paving the way for the wide application of wireless charging technology [14].

4. Conclusion

Electromagnetic induction and magnetic resonance technology are two core technologies of wireless electric vehicle charging, which have great potential in energy saving, environmental protection and intelligent transportation. Electromagnetic induction technology has high efficiency and simple system design, which is especially suitable for short-distance static charging, such as home and parking lot, and its practical application has been very mature. Magnetic resonance technology breaks through the limitation of transmission distance through resonant network, which is more flexible and can penetrate obstacles, so it can realize dynamic charging and energy transmission in complex environment. Electromagnetic induction and magnetic resonance technology have their own advantages in charging efficiency, distance and safety. They complement each other and promote the diversified development of wireless charging technology. However, they also have some problems, such as the strict limitation of electromagnetic induction on the axis of the coil, the difficulty in frequency control of magnetic resonance, and the security risks brought by electromagnetic radiation.

In the future, the progress of wireless charging technology should give priority to improving efficiency, reducing costs and strengthening safety standards. We can achieve these goals by improving coil design, developing new compensation network and adopting adaptive control algorithm, which can improve the efficiency of energy transmission and the stability of the system. In addition, the development of dynamic charging technology will bring breakthrough innovation for long-distance driving of electric vehicles and help them better integrate into intelligent transportation systems. Developing international standards and studying electromagnetic compatibility will also make this technology more popular. Generally speaking, the continuous progress of electromagnetic induction and magnetic resonance technology will inject new impetus into the sustainable development of the electric vehicle industry and promote our vision of low-carbon and environmentally-friendly transportation.

References

- [1] Zhang, C., Wang, Z., Li, Q.: Research status and development trend of wireless charging technology for pure electric vehicles. *Internal Combustion Engine & Parts* (9), 203-205 (2021).
- [2] Lü, L.: Design and analysis of wireless charging system for new energy vehicles. *Agricultural Machinery Using & Maintenance* (10), 46-49 (2023).
- [3] Cheng, X., Ma, X.: Research on wireless charging technology for electric vehicles. *Industrial Control Computer* 30(6), 145-146 (2017).
- [4] Sagar, A., et al.: A comprehensive review of the recent development of wireless power transfer technologies for electric vehicle charging systems. *IEEE Access* 11, 83703-83751 (2023).
- [5] Zhang, Y., Chen, K., He, F., Zhao, Z.: Research on wireless power transfer for electric vehicles: A review. *IEEE Transactions on Power Electronics* 34(8), 7602-7611 (2019).
- [6] Li, S., Mi, C. C.: Wireless power transfer for electric vehicle applications. *IEEE Journal of Emerging and Selected Topics in Power Electronics* 3(1), 4-17 (2015).
- [7] Kurs, A., Karalis, A., Moffatt, R., Joannopoulos, J. D.: Wireless power transfer via strongly coupled magnetic resonances. *Science* 317(5834), 83-86 (2007).
- [8] Triviño-Cabrera, A., González-González, J. M., Aguado, J. A.: Wireless power transfer for electric vehicles: Foundations and design approach. Springer, Cham (2020).
- [9] Covic, G. A., Boys, J. T.: Modern trends in inductive power transfer for transportation applications. *IEEE Journal of Emerging and Selected Topics in Power Electronics* 1(1), 28-41 (2013).
- [10] Hui, S. Y. R., Zhong, W., Lee, C. K.: A critical review of recent progress in mid-range wireless power transfer. *IEEE Transactions on Power Electronics* 29(9), 4500-4511 (2014).
- [11] Ahmad, A., Alam, M. S., Chabaan, R.: A comprehensive review of wireless charging technologies for electric vehicles. *IEEE Transactions on Transportation Electrification* 4(1), 38-63 (2018).
- [12] Bi, Z., Kan, T., Mi, C. C., Zhang, Y.: A review of wireless power transfer for electric vehicles: Prospects to enhance sustainable mobility. *Applied Energy* 179, 413-425 (2016).
- [13] Choi, S. Y., Gu, B. W., Jeong, S. Y., Rim, C. T.: Advances in wireless power transfer systems for roadway-powered electric vehicles. *IEEE Journal of Emerging and Selected Topics in Power Electronics* 3(1), 18-36 (2015).
- [14] Kim, J., Kim, J., Shin, J., Lee, J.: Electromagnetic compatibility of resonance coupling wireless power transfer for electric vehicles. *IEEE Transactions on Electromagnetic Compatibility* 59(5), 1472-1480 (2017).